 Electric heat 3-15 kW

4 models

CE

Jaguar

Portable fan heater with exclusive design and built-in timer

Jaguar is a range of portable fan heaters with exclusive design and built-in timer.

Fan heater Jaguar blends well into the environment with the stylish casing and quiet fan without compromising performance.

Jaguar is suitable for temporary or permanent heating in stores, showrooms, offices etc. where additional heat is needed.

- For fixed installation or portable use.
- Corrosion resistant casing of hot zinc-plated stainless steel. Colour: casing in silver. Grille and bracket: RAL 3020 (red)
- Variable thermostat, +4 to +40°C.
- Switchable to or off- delay (0-24 hours).
- Connection voltage J3: 230V~. Connection voltage J5, J9 and J15: 400V3N~.
- Low temperature casing.

Technical specifications | Fan heater Jaguar ⚡

Type	Output stages [kW]	Airflow [m³/h]	Voltage [V]	HxWxD [mm]	Weight [kg]
J3	2/3	200/290	230V~	374x359x411	8.0
J5	2.5/5	300/480	400VN3~	374x359x411	8.1
J9	4.5/9	590/710	230VN3~	429x428x478	14
J15	7.5/15	880/1100	400V3~	500x500x543	20

Protection class Jaguar: IPX4.

Approved by SEMKO and CE compliant.

Dimensions

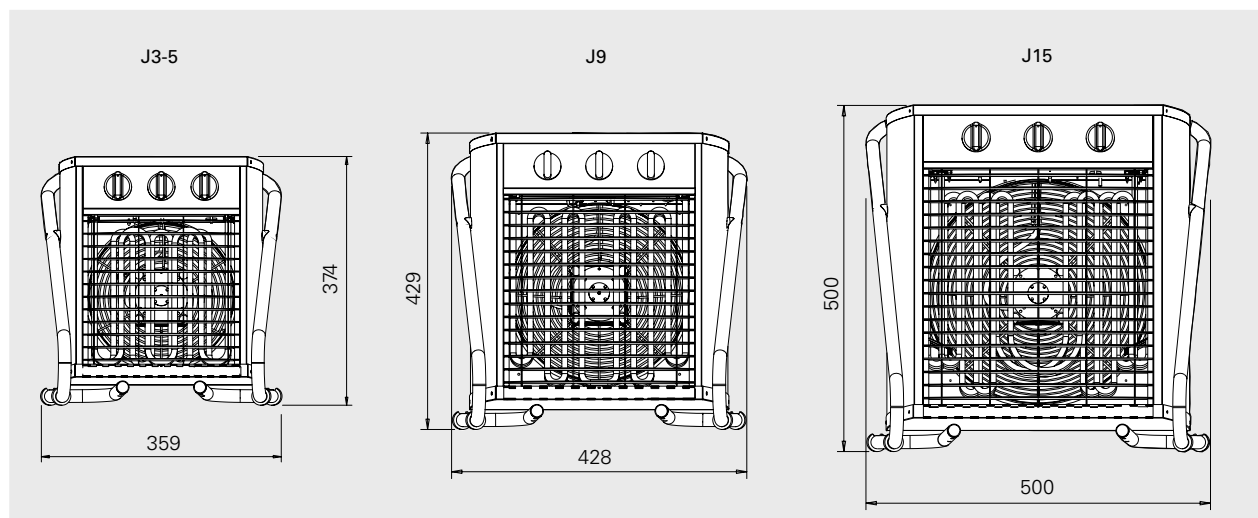

Mounting

Jaguar can be mounted on the wall or be used as a portable fan heater. The rails make the fan heater steady when used as a portable fan heater.

The bracket (extra) allows Jaguar to be mounted on the wall at different angles; sideways +/- 30° or downwards 7.5°, 15°.

Jaguar has a built-in variable thermostat with working range +4°C to +40°C and a timer with start delay (0- 24 hours).